

# Wave Propagation Study in a Fluid Filled Borehole – Finite Difference Simulations

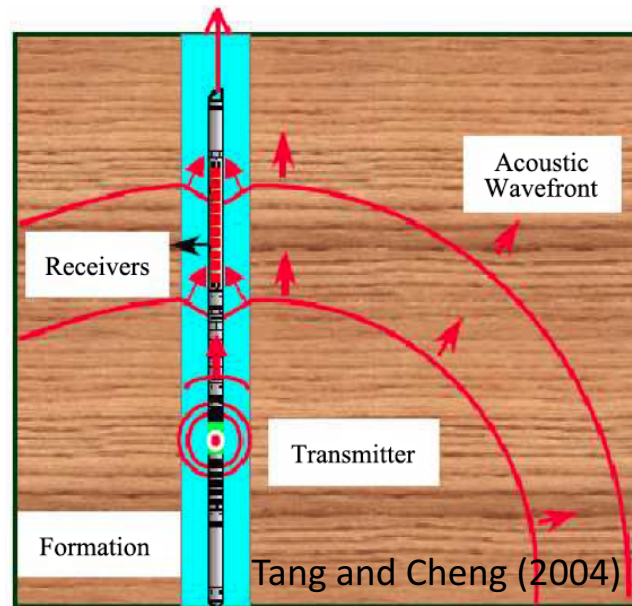

Chen Gu



# Outline

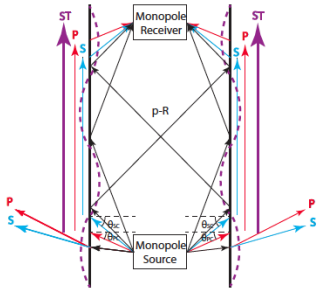

- Theoretical background – Wave modes in a borehole

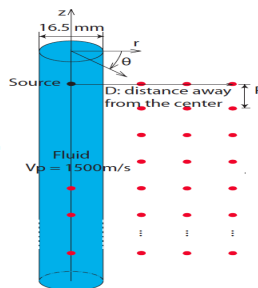

- Methodology – Finite difference simulation

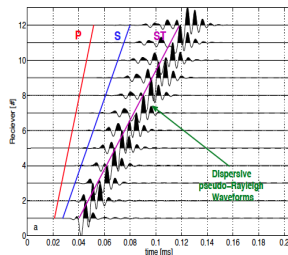

- Results and discussion – Full wave propagation in a borehole



# Wave modes generated in hard formation with a monopole source

- Body waves: Compressional (P) and Shear (S) waves
- Guided waves: Stoneley (ST) and pseudo-Rayleigh (p-R) waves

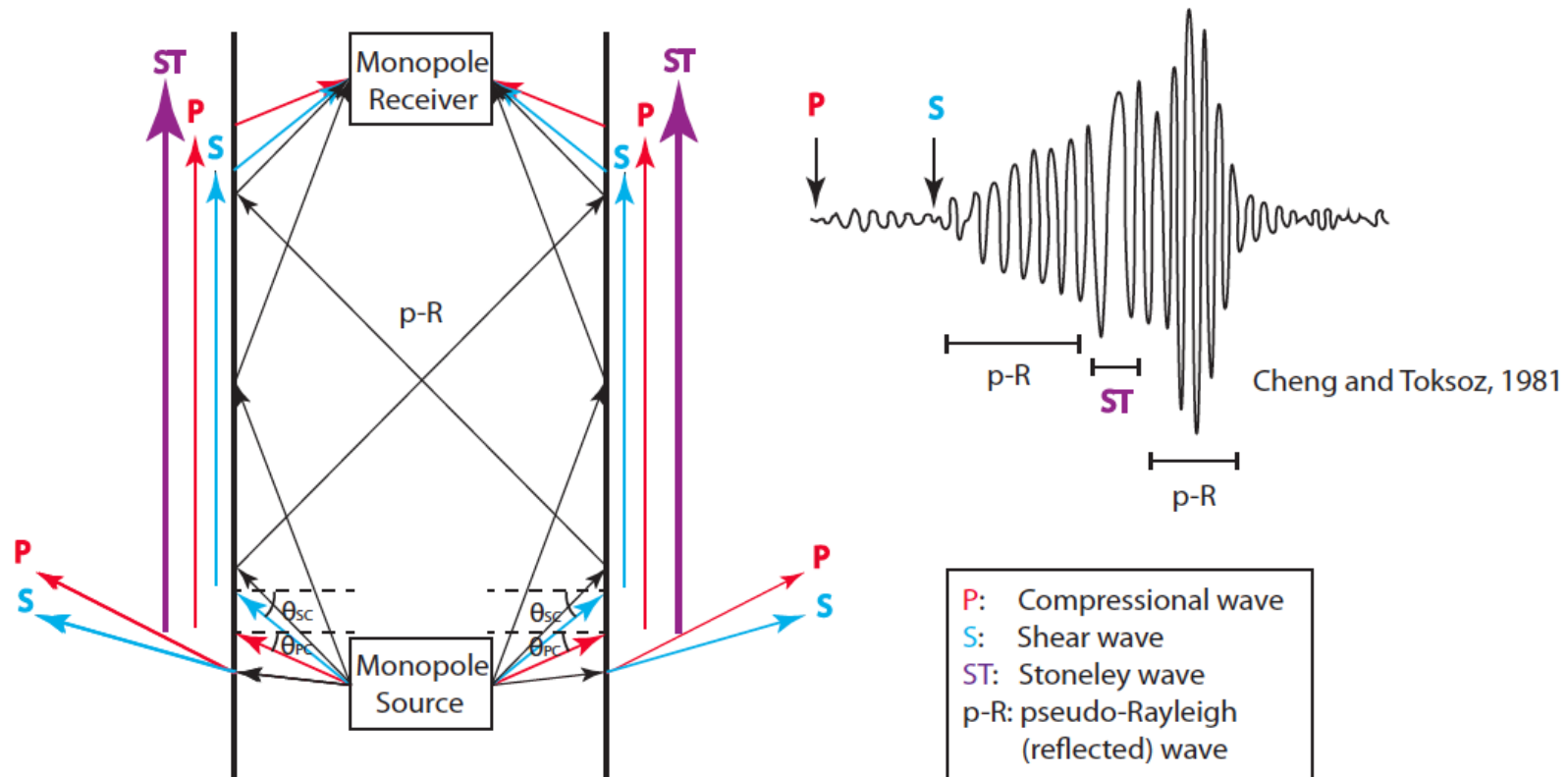

# Dispersion curves for slow and fast formations

## Slow formation

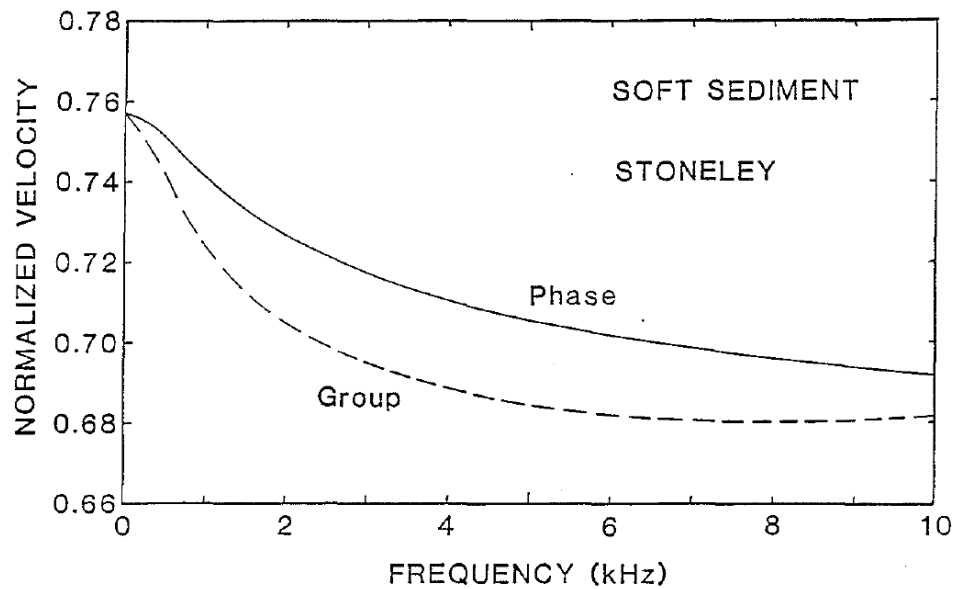

## Fast formation

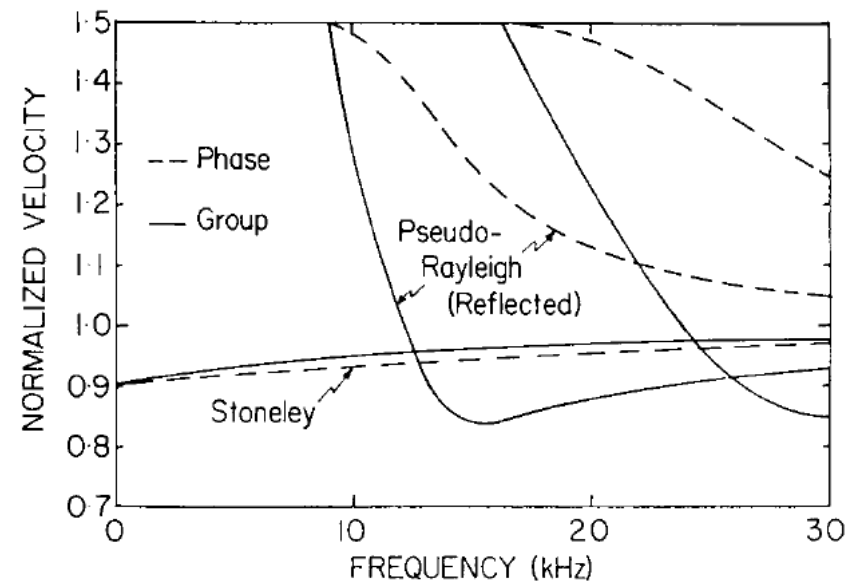

Cheng and Toksoz, 1981, 1983



# Wave modes generated in hard formation with a dipole source

- Body waves: Compressional (P) and Shear (S) waves
- Guided waves: Flexural waves

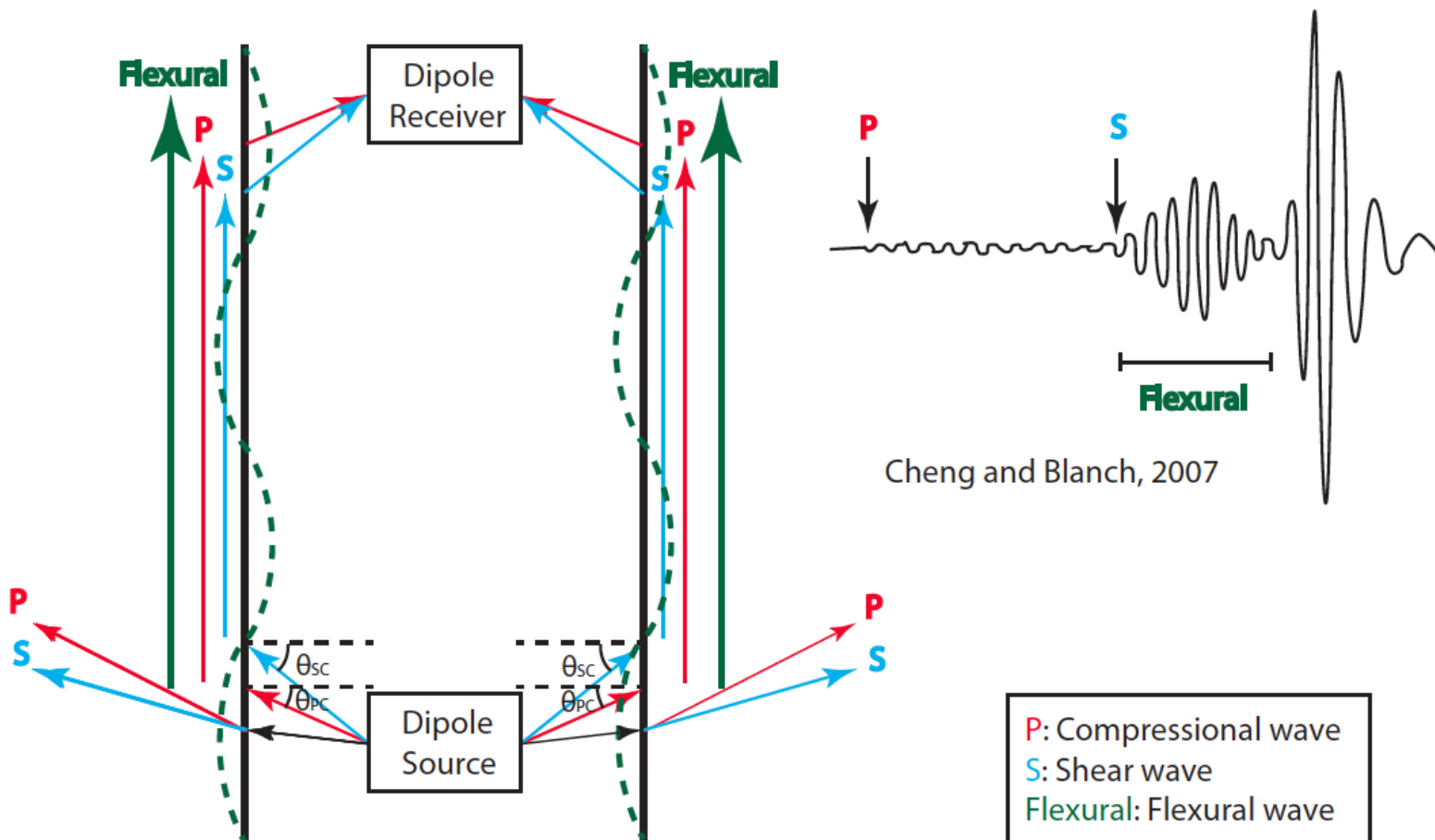

# Wave equations in a borehole

- Wave propagation equation

$$(\lambda + \mu)\nabla(\nabla \cdot \vec{u}) + \mu\nabla^2\vec{u} + \rho\omega^2\vec{u} = 0$$

- Boundary conditions

$$\left\{ \begin{array}{l} u = u_f \\ \sigma_{rr} = \sigma_{rrf} \\ \sigma_{rz} = 0 \\ \sigma_{r\theta} = 0, \end{array} \right.$$



# Finite difference method

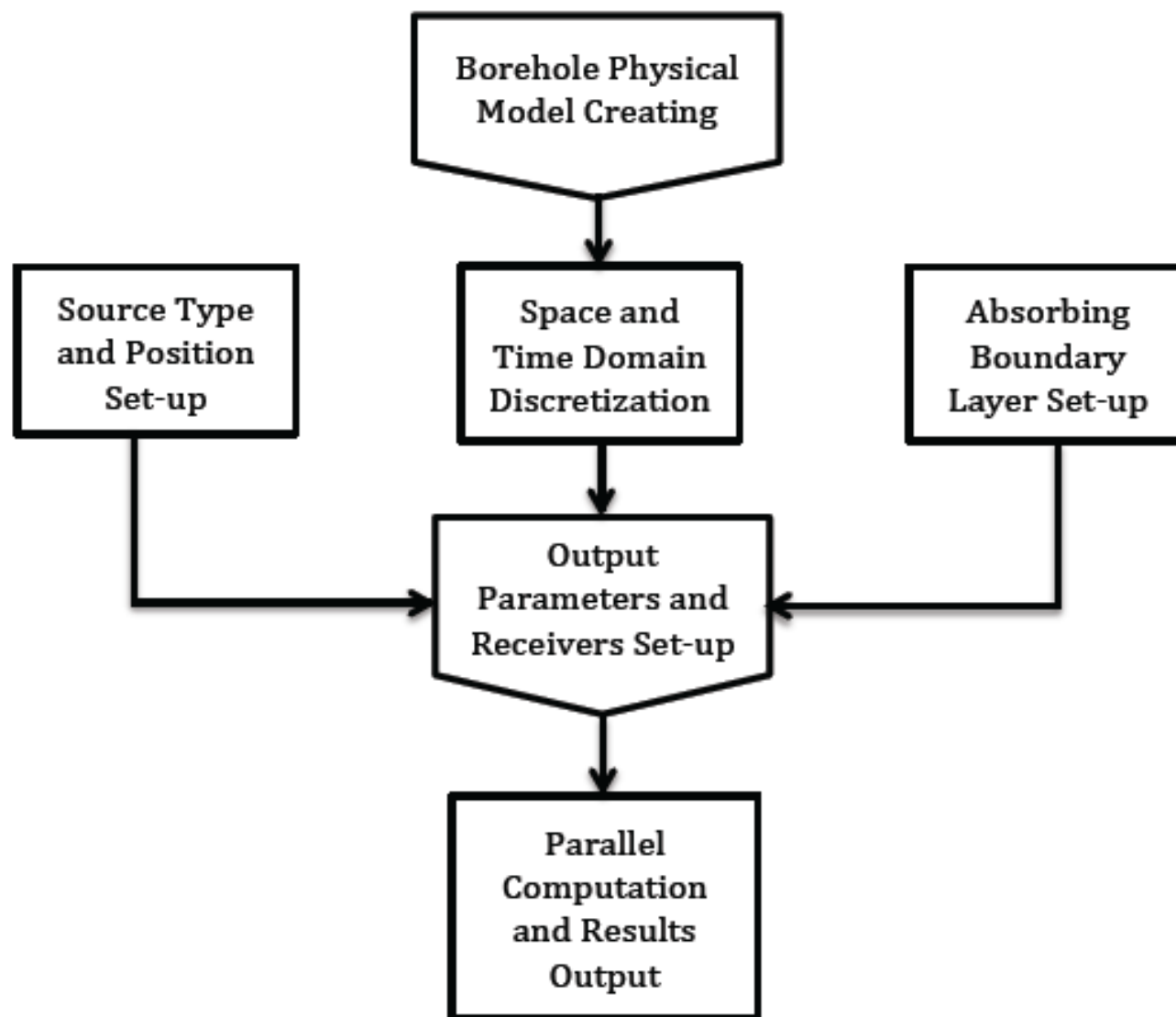

# The two-layer finite difference model

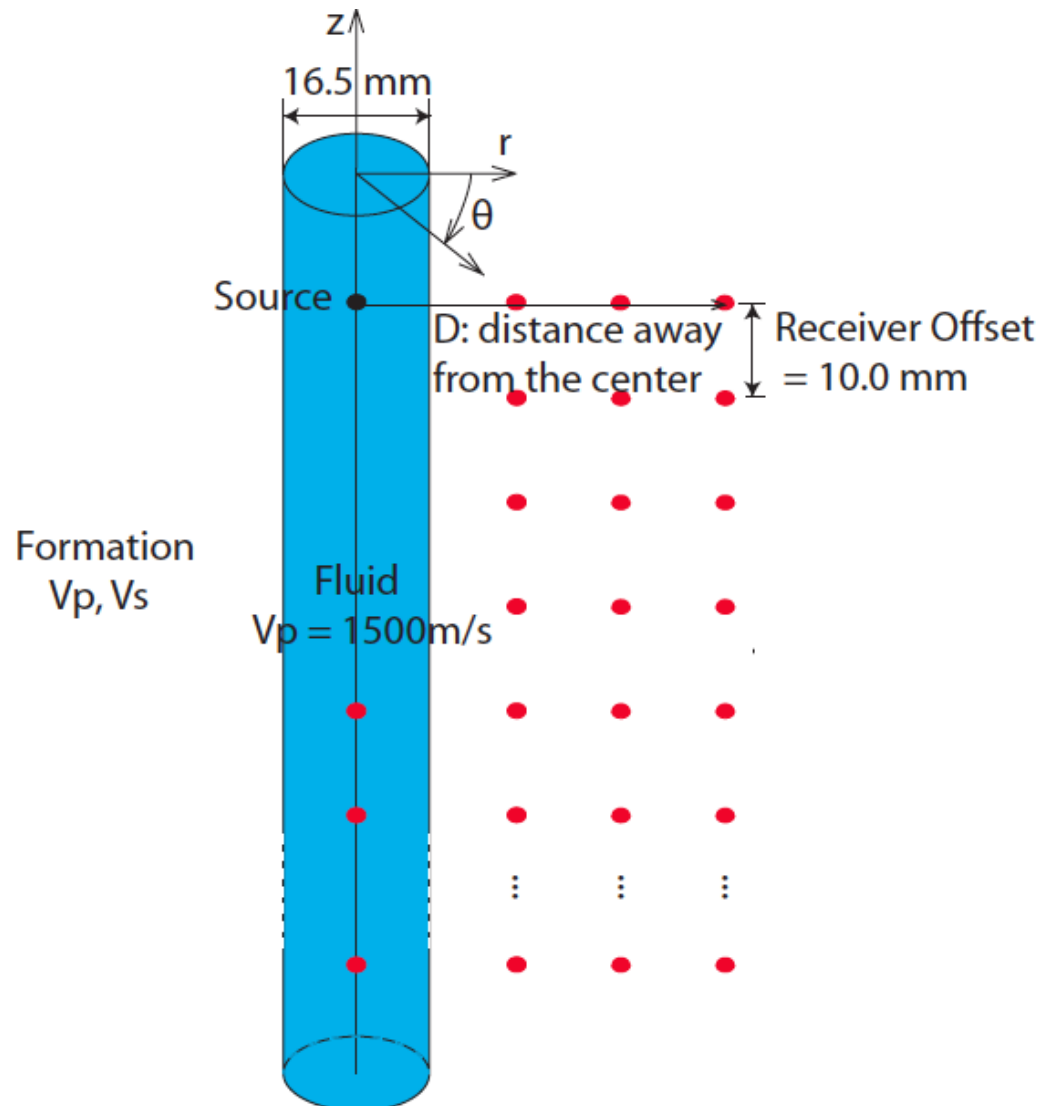

# Wave fields inside a borehole with soft formation

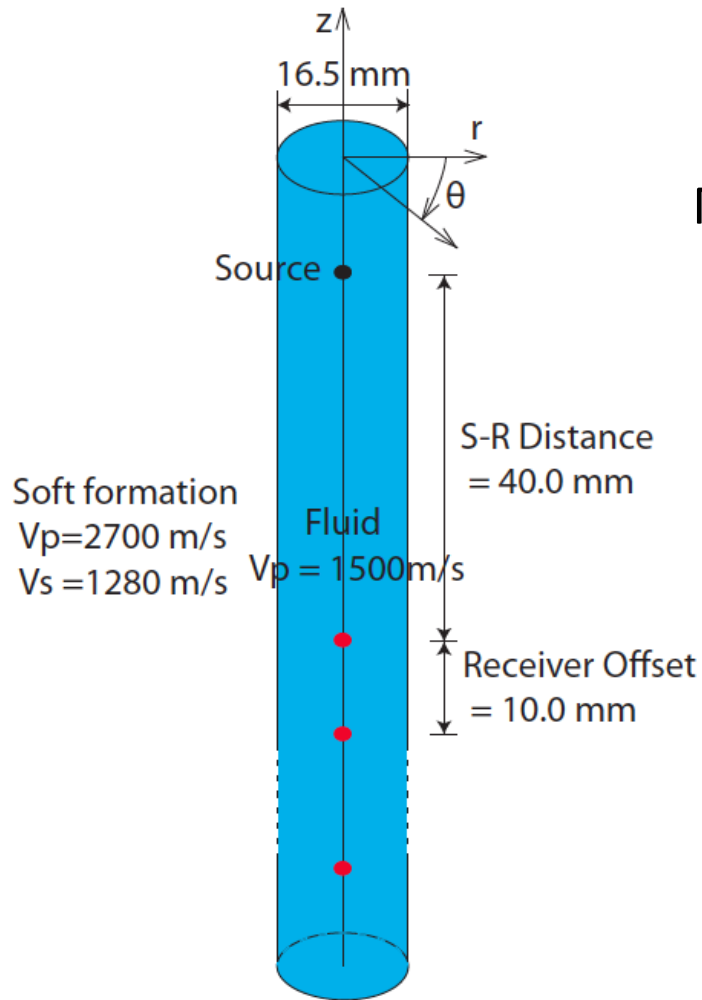

Monopole

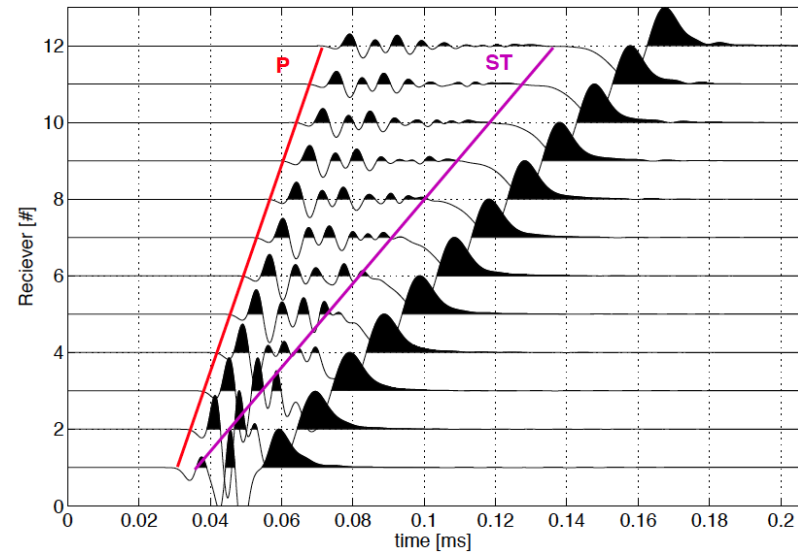

Dipole

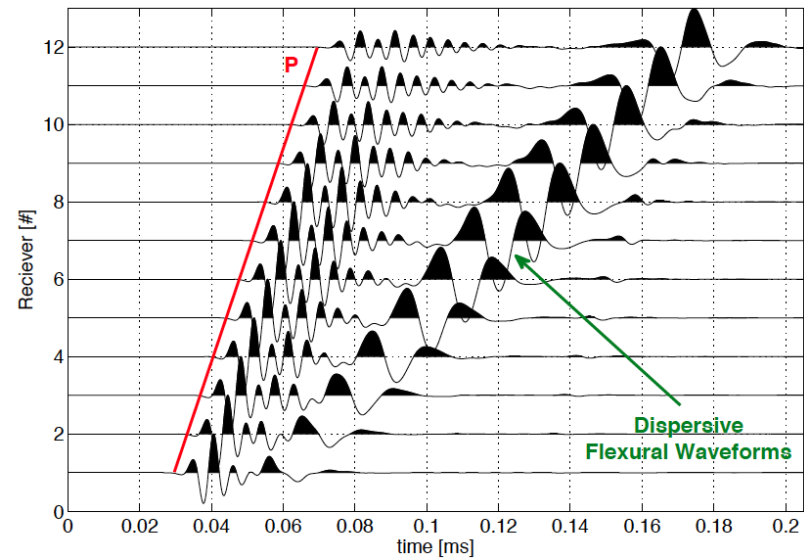

# Wave fields inside a borehole with hard formation

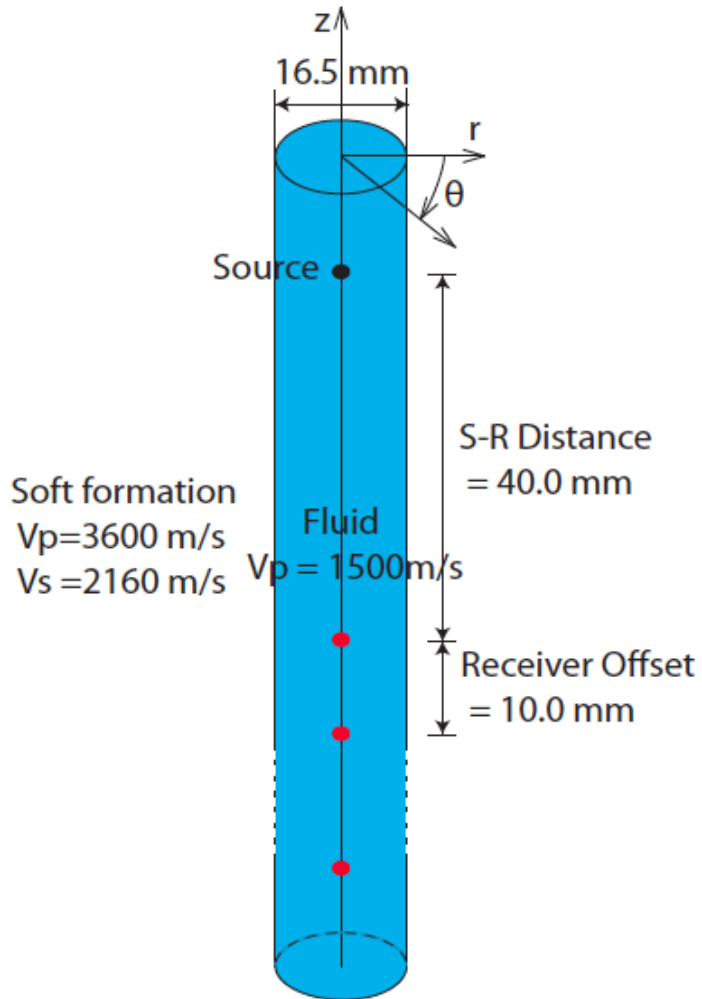

Monopole

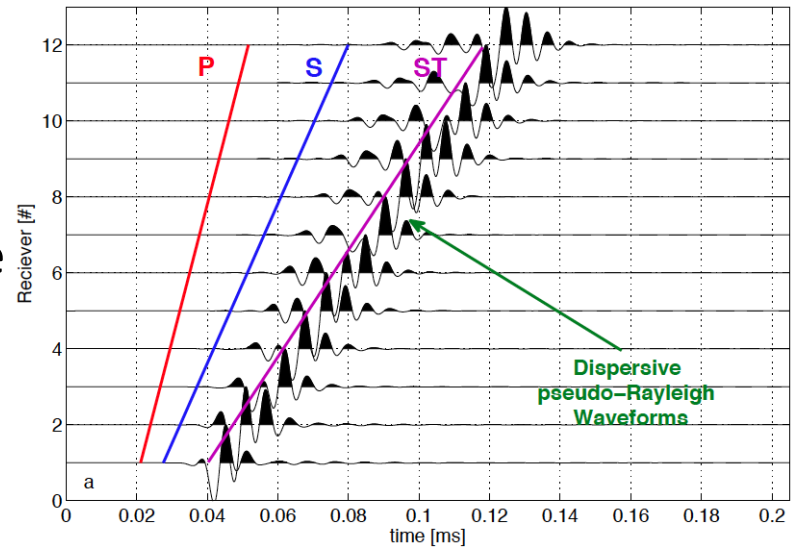

Dipole

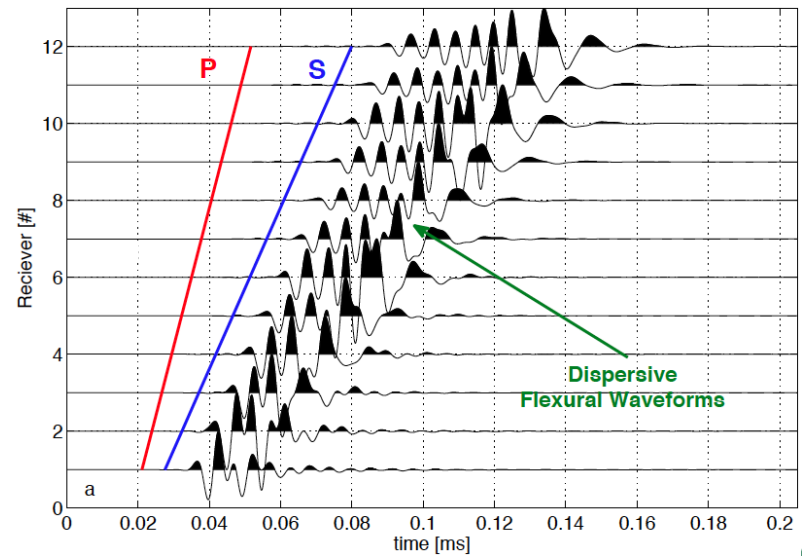

# Wave fields in hard formation outside a borehole with a distance one half wavelength of S-wave from the wall

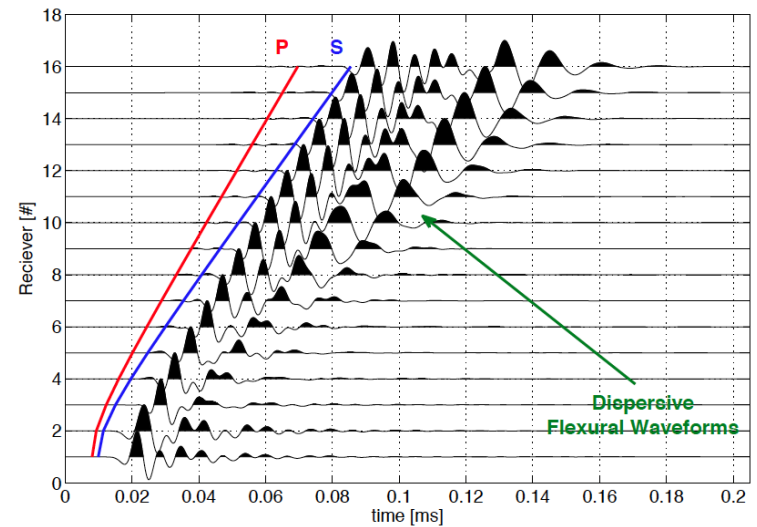
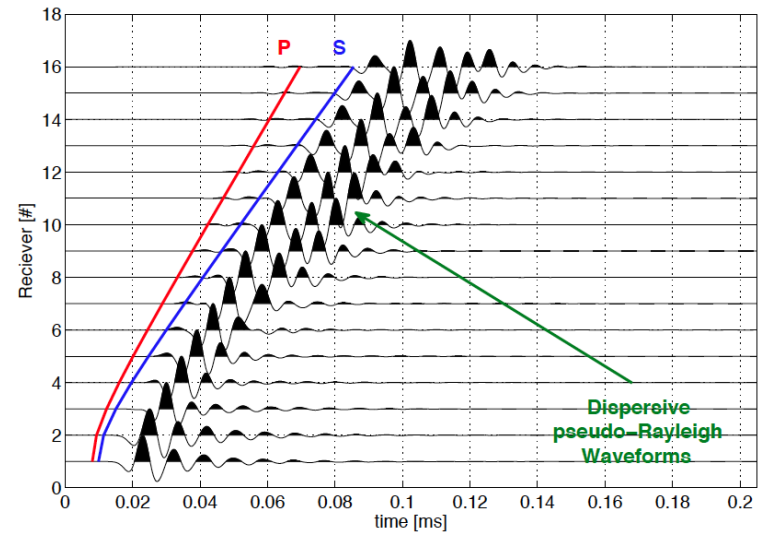
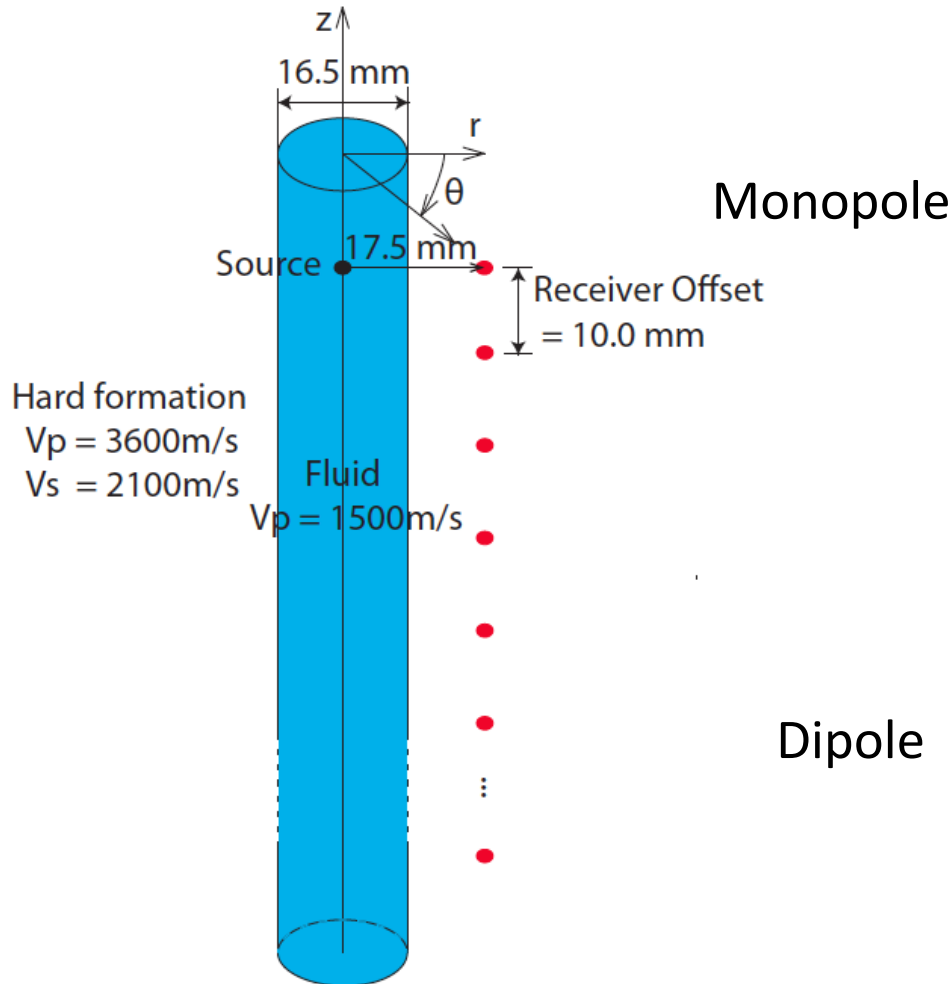

# Wave fields in hard formation outside a borehole with a distance one wavelength of S-wave

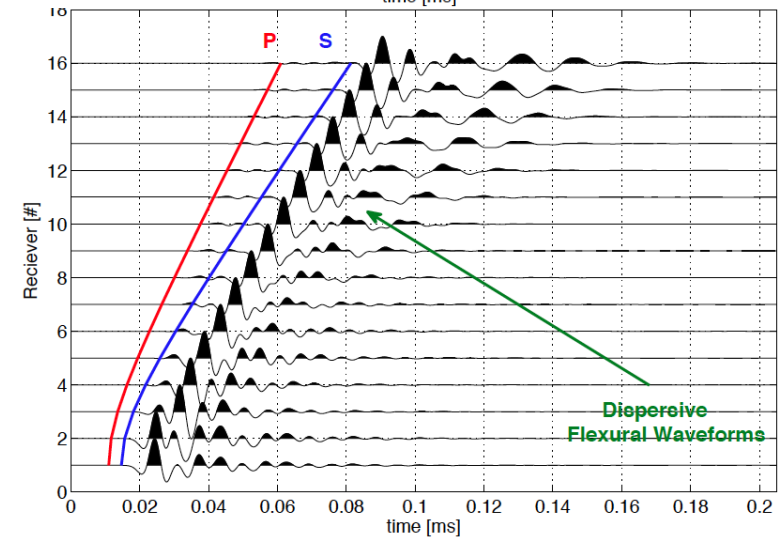
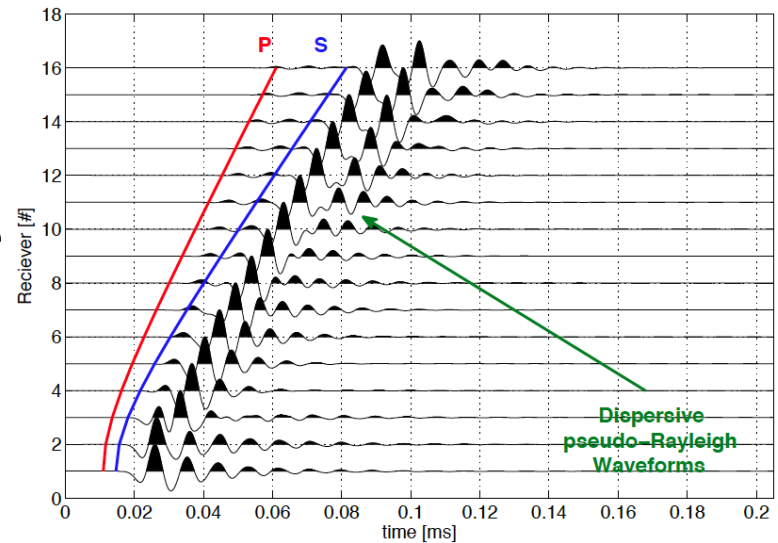
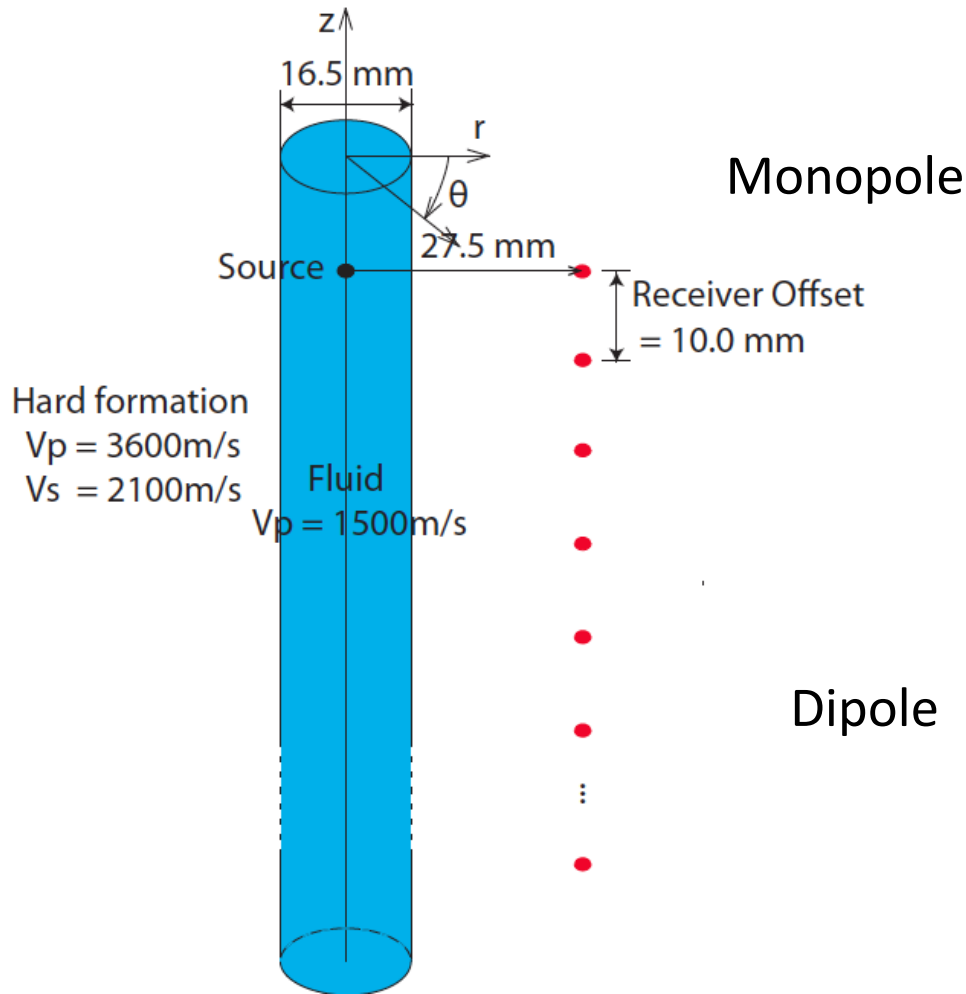

# FD simulation results of the 2D cross-section of the concrete borehole model

## Monopole

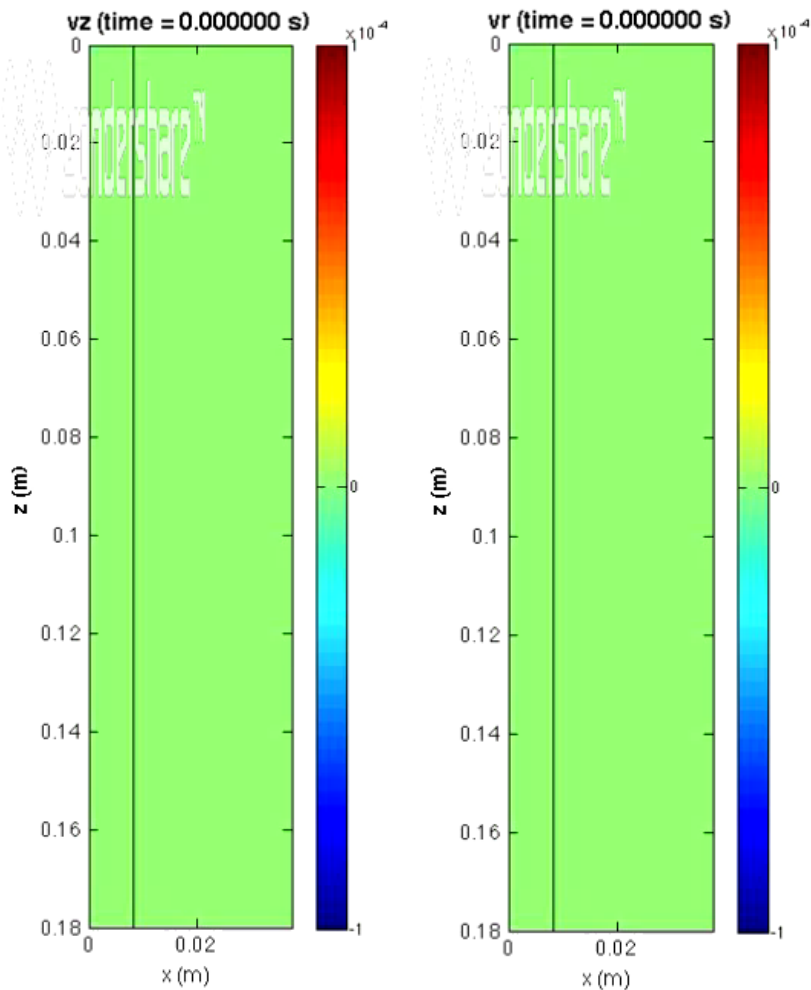

## Dipole

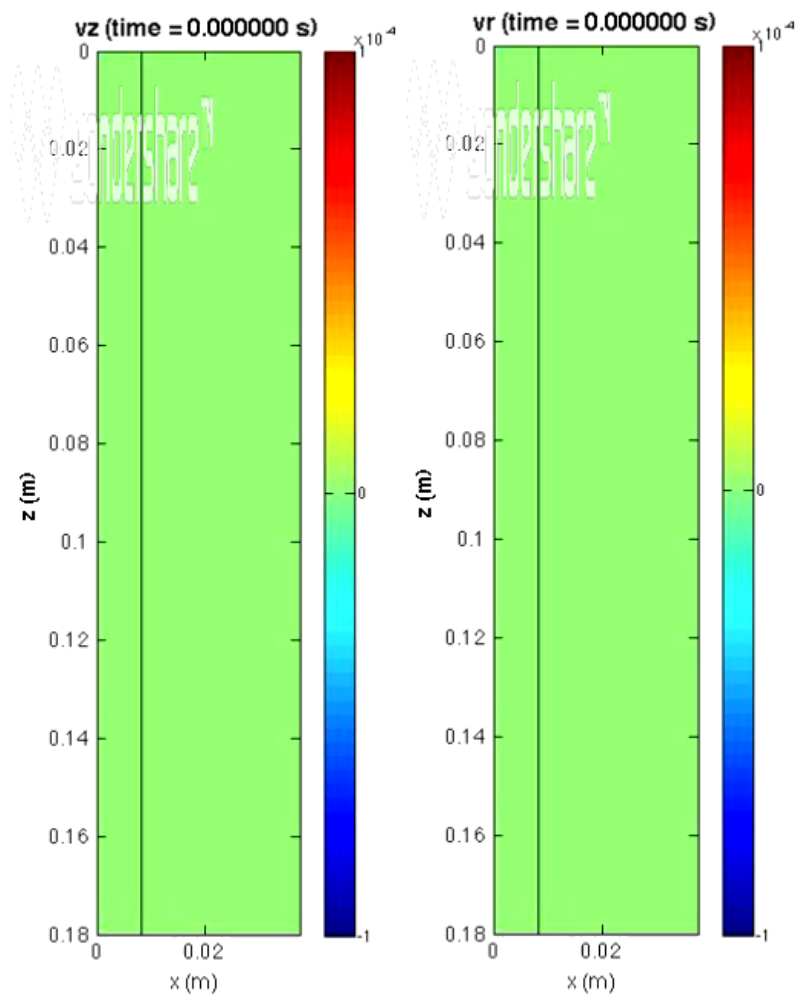

# Summary

- Our finite difference simulation results show different wave modes in soft- and hard-formation borehole models with monopole and dipole sources.
- Most of the energy radiated by the source are confined inside the borehole.
- Inside a borehole, the guided waves (ST, p-R, flexural waves) carry most of the energy; outside a borehole, the guided waves decays exponentially away from the borehole.

